

Art. nr. 91006773-02

Omschrijving: L150-anker 150x60 70x8, TV

Materiaal: S235

Behandeling: Thermisch Verzinkt

Verpakkingshoeveelheid: 1 st.

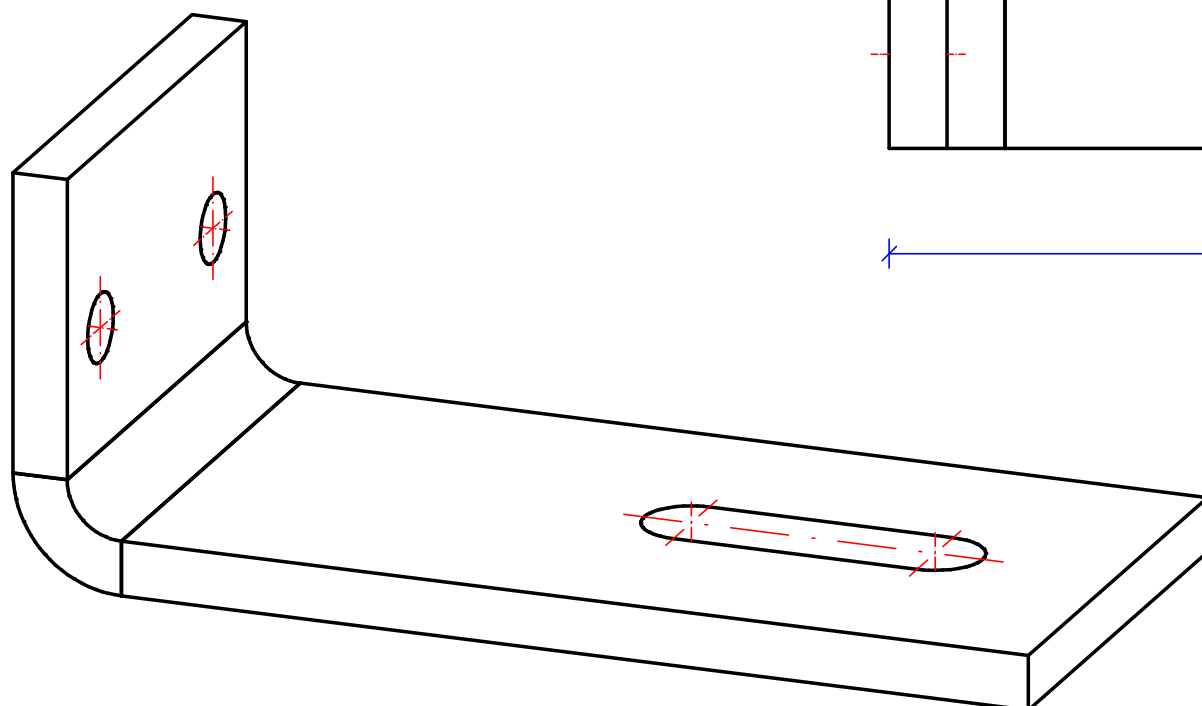
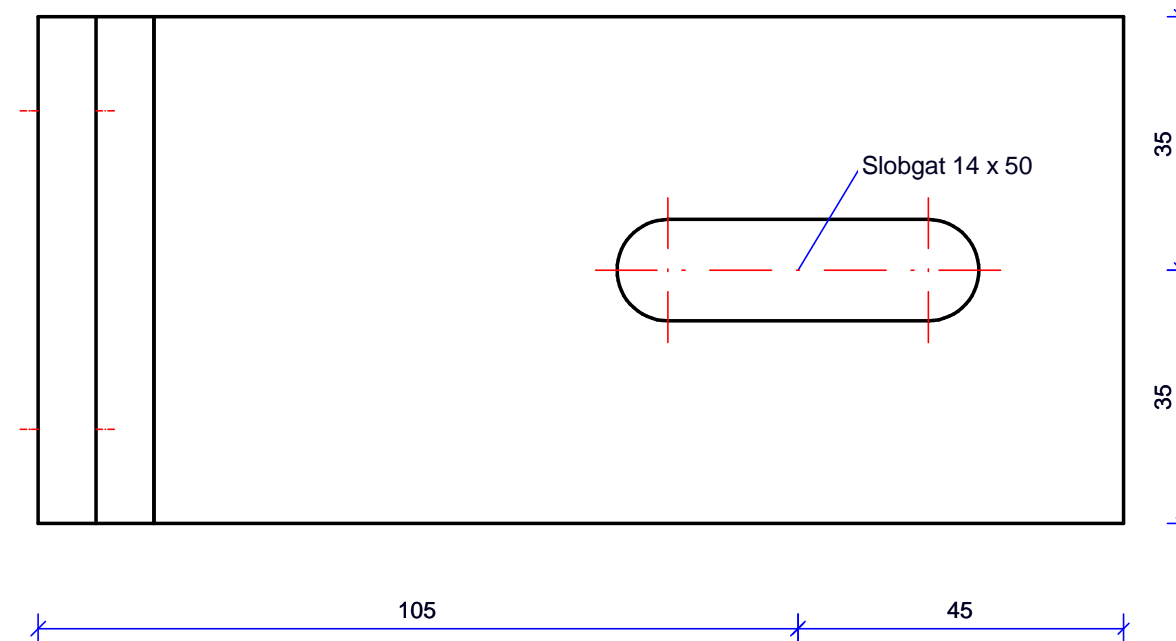
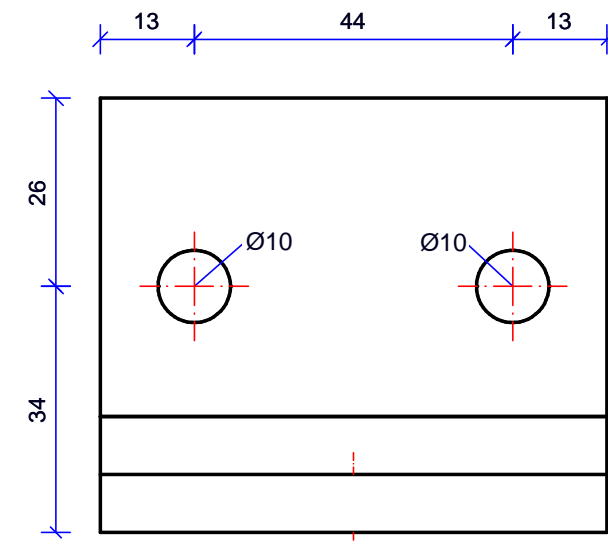
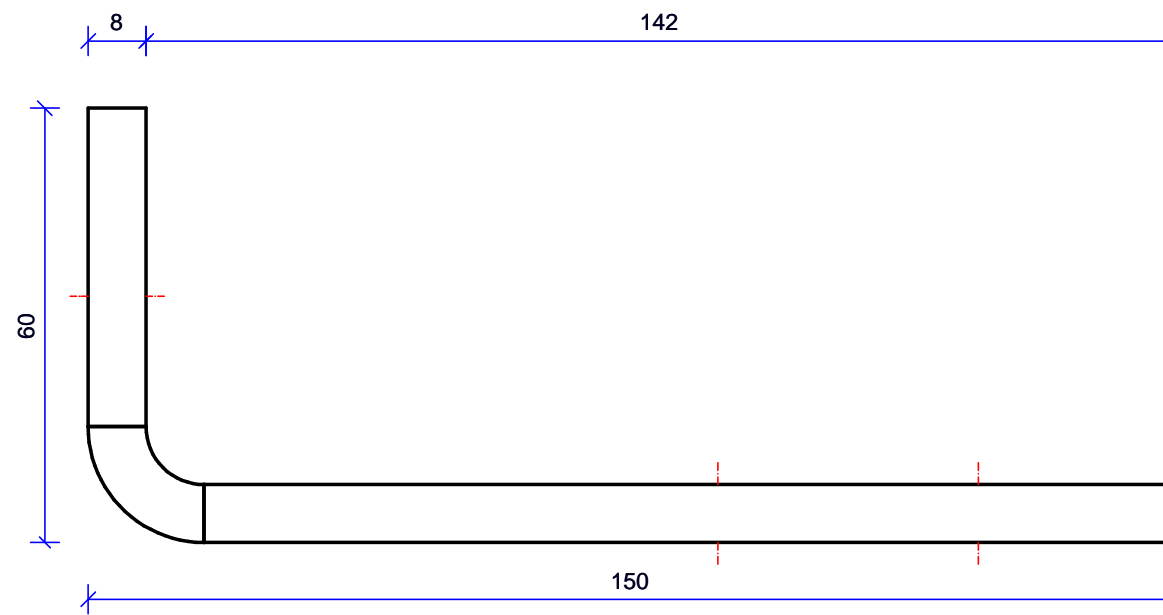
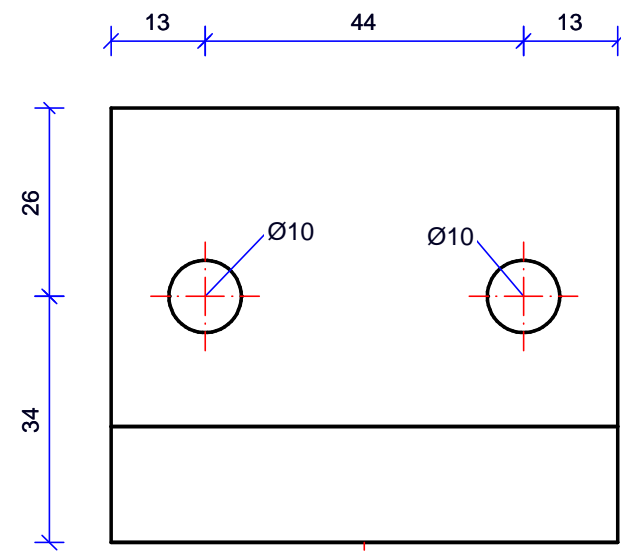

E-mail: verkoop@jonkers-bouwmetaal.nl

Adres: Hoornse Hop 10, 8321 WX Urk

Telefoon: 0527-685156

Website: www.jonkers-bouwmetaal.nl

