

Art. nr. 91012365

Omschrijving: HXL02-anker 150x75 72x5

Materiaal: Sendzimir Verzinkt

Behandeling: N.V.T.

Verpakkingshoeveelheid: 25 st.

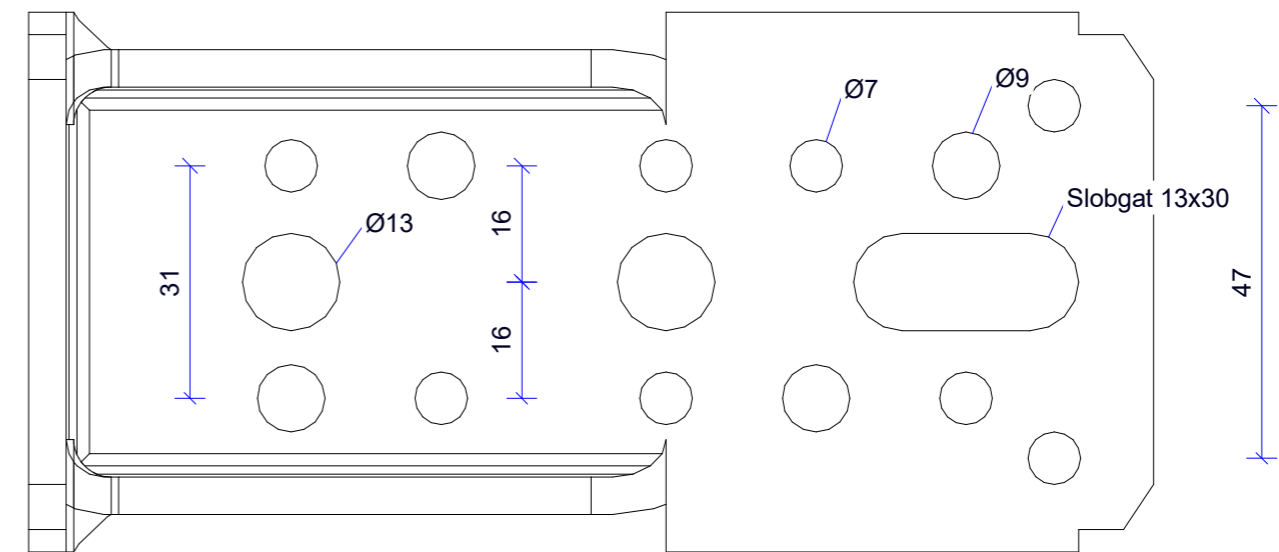
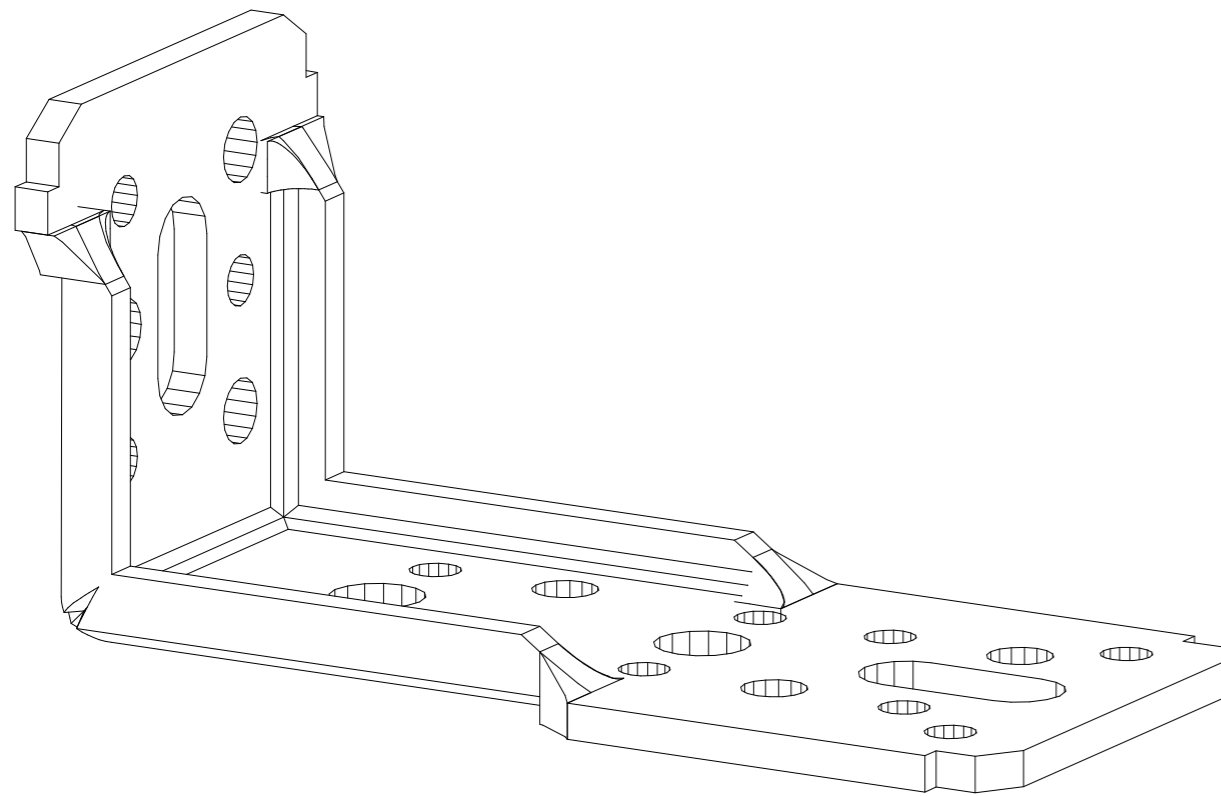
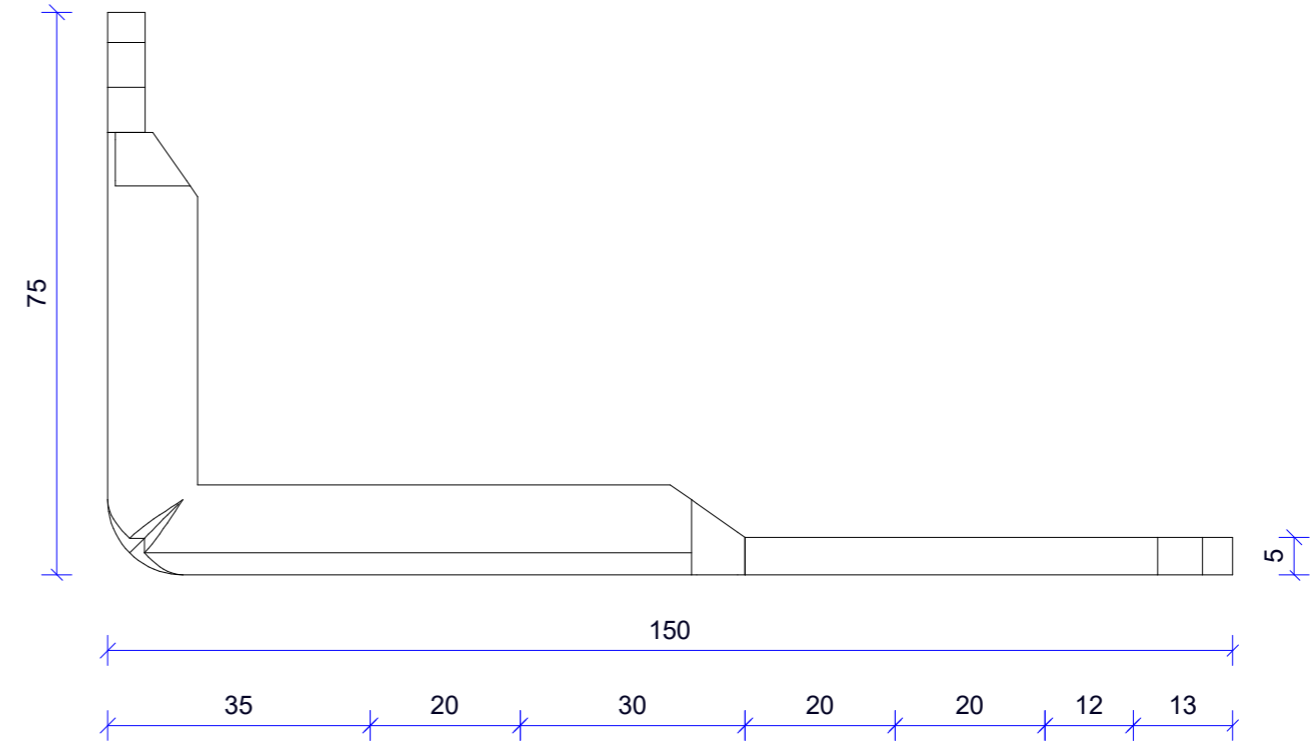
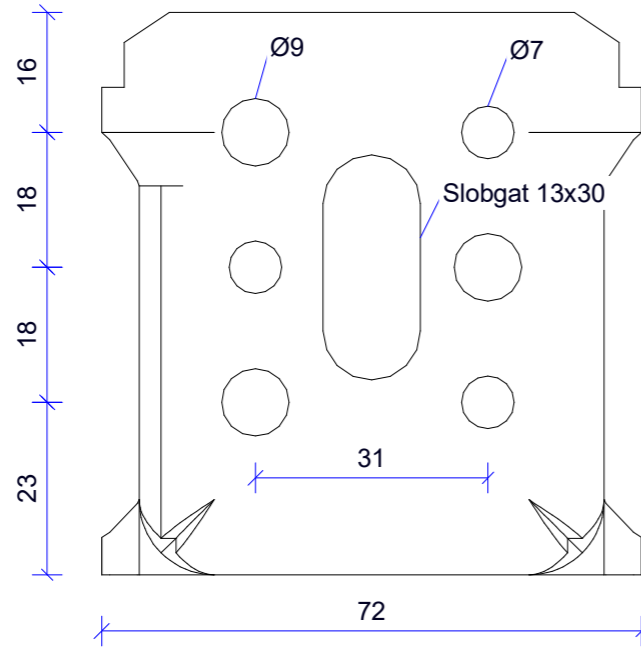

E-mail: [verkoop@jonkers-bouwmetaal.nl](mailto:verkoop@jonkers-bouwmetaal.nl)

Adres: Hoornse Hop 10, 8321 WX Urk

Telefoon: 0527-685156

Website: [www.jonkers-bouwmetaal.nl](http://www.jonkers-bouwmetaal.nl)

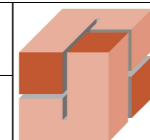

**JONKERS**  
BOLWVERANKERING

Onderdeel van

1.11.2024