

Art. nr. 91006423

Omschrijving: L02-anker 500x80 60x10

Materiaal: S355

Behandeling: Thermisch Verzinkt

Verpakkingshoeveelheid: 1 st.

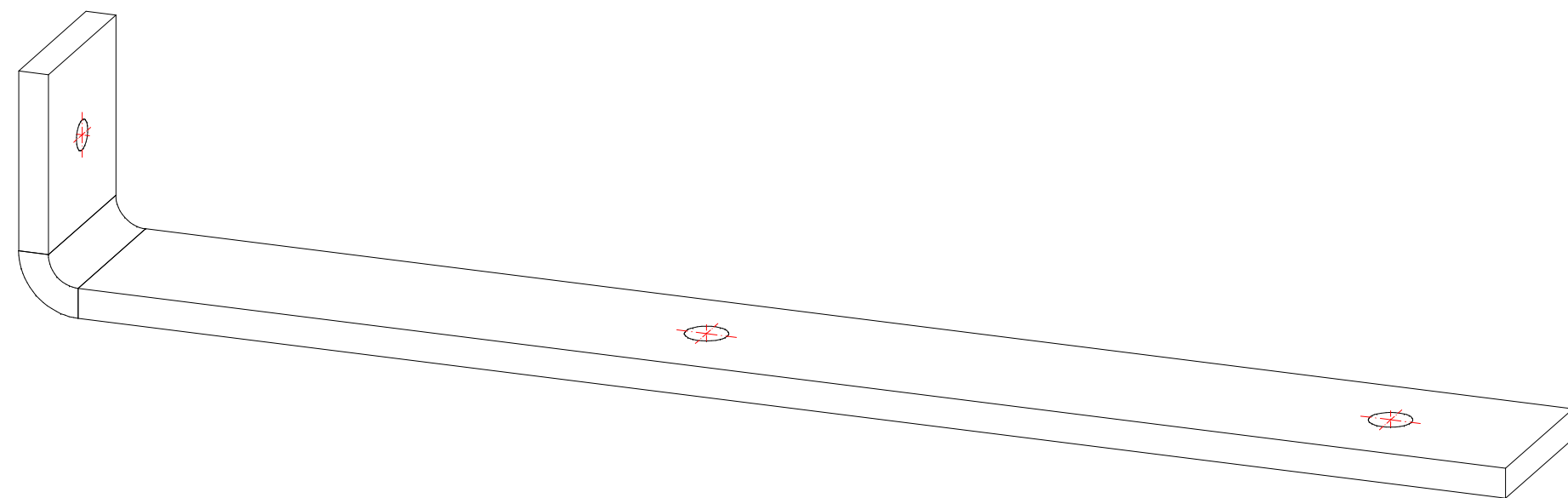
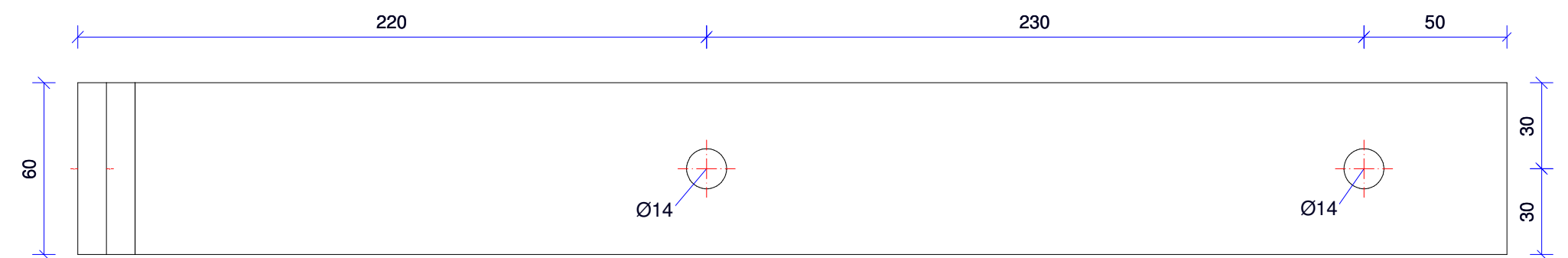
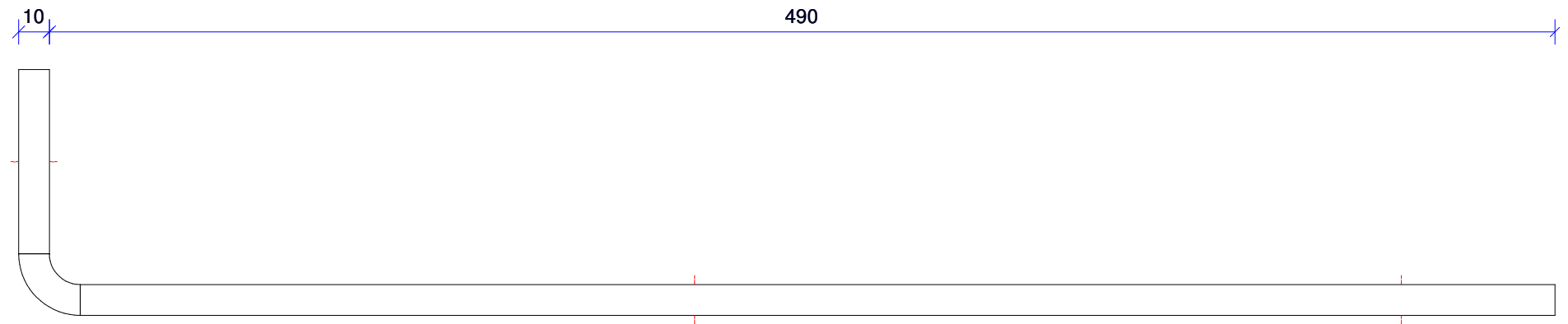
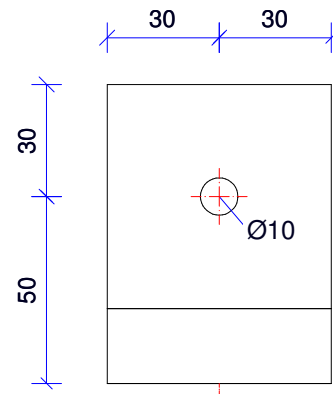

E-mail: [verkoop@jonkers-bouwmetaal.nl](mailto:verkoop@jonkers-bouwmetaal.nl)

Adres: Hoornse Hop 10, 8321 WX Urk

Telefoon: 0527-685156

Website: [www.jonkers-bouwmetaal.nl](http://www.jonkers-bouwmetaal.nl)

